

The HC-33/U provides a broad range of frequencies, packaged in a robust, high reliability enclosure. It is a proven long term product, serving military low frequency replacement parts, Q.P.L., and Government programs.

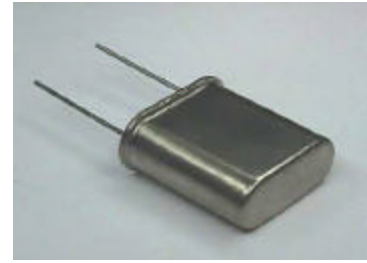

ADVANTAGES

- 4High Shock and Vibration
- 4Hermetic Package
- 4Wide Operating Frequency

APPLICATIONS

- 4Telecommunications
- 4Avionics
- 4Military

ELECTRICAL PERFORMANCE (Ta=25°C)

PARAMETER	MINIMUM	MAXIMUM	UNITS	
Center Frequency	500.00KHz	350.00MHz		
Oscillation Mode	Fundamental, 3 rd , 5 th , and 7 th			
Maximum Series Resistance (See Note 4)	25.0	1000.0	Ohms	
Frequency Stability at +25°C (See Note 2)	±50.0ppm Typ.	±5.0	±100.0	ppm
Frequency Stability Over Temperature	±50.0ppm Typ.	±5.0	±100.0	ppm
Operating Temperature Range (See Note 2)	-20	+70	°C	
Storage Temperature Range	-55	+125	°C	
Drive Level	100.0uW Typical			
Seal Method	Resistance Weld			
Shunt Capacitance	1.0	5.0	pF	
Motional Capacitance	Customer Request			
Load Capacitance			pF	
Aging per year	±1.0	±5.0	ppm	

Parameter	Standard Observed
Mechanical Shock	MIL-STD-202 Method 213, Condition C
Vibration	MIL-STD-202 Method 201, 204, and 214
Hermeticity	MIL-STD-202, Method 112
Solderability	IPC/EIA-STD-002A

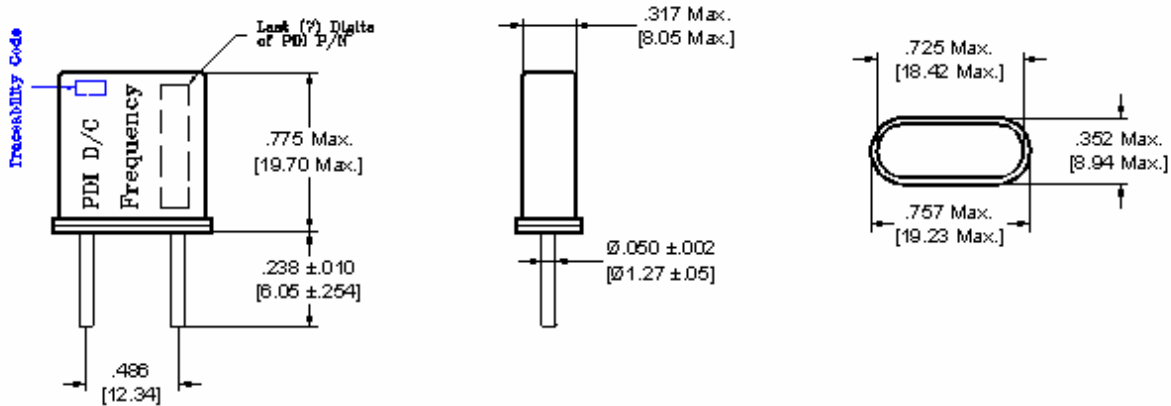

- NOTES**
- 1) To order, state part number, options and nominal frequency e.g. HC-33/U 100.000MHz
 - 2) Other temperature ranges, stabilities and electrical parameters are readily available upon request.
 - 3) Other specifications available upon request.
 - 4) Dependent on frequency and mode

Precision Devices INC. – 8840N. Greenview Drive, Middleton WI 53562, Tel- 1-800-274-XTAL, Fax- 1-608-831-3343, www.pdixtal.com Outside US Phone- 608-381-4445, E-mail- sales@pdixtal.com
 PD (HK) Ltd. – Tel- (852)-2367-3626, Fax- (852)-2646-3122, E-mail- sales@pdixtal.com.hk
 PD (UK) Ltd. – Tel- +44 (0)1223 834444, Fax- +44(0)1223 834589, E-mail- sales@pdixtal.co.uk